



Section J

Body Mounting

Contents

Modification Code J4 — Tipper Bodies	2
1. Scope	2
2. Related standards	2
3. Certification procedure	2
4. Design requirements	2
5. Body Props	4
6. Tail Gates, Grain and Inspection Chutes.	4
7. Load Cells	4
8. Hydraulics/Pneumatics	5
9. Alarms, warnings and lockout features	6
10. Controls	6
11. Wiring	76
12. Marking	76
13. Stability	7
14. Stability calculations	87

Modification Code J4 — Tipper Bodies (Design)

1. Scope

This modification code provides the standards that must be met when designing tipper bodies. It provides standards relating to all aspects of tippers such as stabilitysafety, hydraulic, warning devices, etc.

➤ These standards are to be followed when designing a tipper body for a motor vehicle. When certifying an OEM tipper body to, the OEM's design requirements only J1 certification is requiredtake precedence over the standards listed in this

Modifications covered under this code:

Covered

- Certifying motor vehicle tipper body design to J4 requirements

Not covered

- Fitment of a tipper body (see VSB6 Modification Code J1)
- Fitment of an OEM tipper body (see VSB6 Modification Code J1)
- Fitment of non-tipping bodies (see VSB6 Modification Code J1)
- Design of tilt slide owing-bodies (see VSB6 Modification Code T2)
- Fitment of tilt slide owing-bodies (see VSB6 Modification Code T1)
- Fitting a tipper body to a trailer

2. Related standards

Modified vehicles must comply with all ADRs, Australian Standards, acts and regulations. Below are some but not all of the areas that may be affected by the modifications in this code and require certification testing or evidence to demonstrate compliance.

The certifier must ensure that the modified vehicle continues to comply with all related Australian Design Rules and VSB6 codes.

This...	Must comply with...
Lights	ADR 13/..
Mudguards	ADR 42/..
Vehicle dimensions.	ADR 43/..
Chassis modification	VSB6 Modification Code H
Exhaust repositioning	ADR 42/.. VSB6 Modification Code A4

3. Certification procedure

The certification procedure for this modification code is as follows:

1	Modifier	Determine if the tipper body has had previous J4 certification or is an OEM design. <ul style="list-style-type: none"> • If yes, proceed to step 2. • If no, proceed to step 3.
2	Modifier	Contact an accredited J1 AVE to organise the vehicle to be inspected and the tipper body installation certified. <u>Proceed to step 7</u>
3	Modifier	Consult with an accredited J4 AVE for guidance on how to design the tipper body.
4	J4 AVE	Design the body in accordance with the J4 design code.

5	J4 AVE	Certify design and issue a modification certificate and associated documentation.
6	Modifier	Perform modification in accordance with J4 design.
7	Modifier	Contact an accredited J1 AVE to organise the vehicle to be inspected and the tipper body installation certified.
7	J1 AVE	J1 AVE issues modification certificate, affixes modification plate, and submits paperwork as required by the relevant AVE registration scheme.

AVEs must be satisfied that the vehicle modification requirements are being met. It is advised that before design or modifications are carried outbegin the modifier, they are discusses the design/modification ed with the certifying AVE.

4. Design requirements

In addition to designing the tipper body in accordance with the mounting requirements of VSB6 Modification Code J1, the below section is to be followed.

➤ Some work sites may require tippers to meet additional Australian Standards or workplace health and safety requirements. It is recommended that operators ascertain operating conditions, standards applicable, or other procedures applicable to the tipping body, and discuss with the Approved Vehicle Examiner prior to the start of manufacturingIt is recommended that operators ascertain any standards that may be required for their operational needs and advise the Approved Vehicle Examiner.

Tipper bodies should have a continuous sub-frame mounted securely on the chassis. The sub-frame should be mounted by outrigger or fish plate mounts that provide a strong integral structure for mounting attachments such as hoist, tipper body pivots and guide brackets.

All loads should be distributed over the maximum possible length of the chassis.

Required:

- The leading edge of the a sub-frame must provide a progressive load bearing transition gradual reduction in stiffness to prevent truck chassis damage as outlined in J1
- Body guides (gGuide vanes) or equivalent structure must be installed to prevent the front of body from moving side to side (see Figure 1).

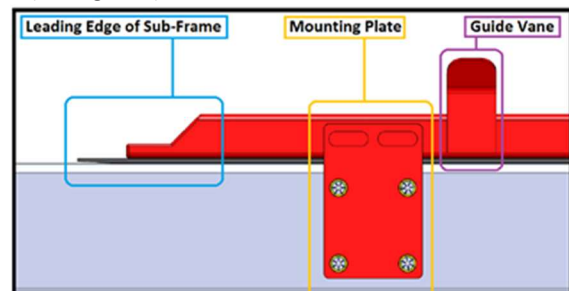

Figure 1 - Example of a suitable sub-frame leading edge, mounting Plate and Body guide (Guide Vane). Note additional examples in Modification code Section J (J1)

- Adequate mounting plates must be mounted near the hoist ram cross-member to provide restraint during tipping operations. These plates must be suitably welded-attached to the sub-frame and attached-affixed to the truck chassis as per

the truck manufacturers' body builders guidelines requirements. In the absence of a truck manufacturers' body builders guidelines, the plates must be mounted to the chassis using a minimum ISO Grade 8.8 (or SAE Class 5), appropriate grade washers and self-locking nuts (see AS 1110.1) high tensile bolts using a minimum ISO Grade 8.8 bolts (or SAE Class 5), hardened washers and self-locking locking nuts. (refer Section H for drilling of chassis) (see Figure 2).

It is preferred that mounting plates are welded to the sub-frame. However, were bolted the AVE must ensure the attachment is suitably design (crush tube, self-locking nuts, etc)

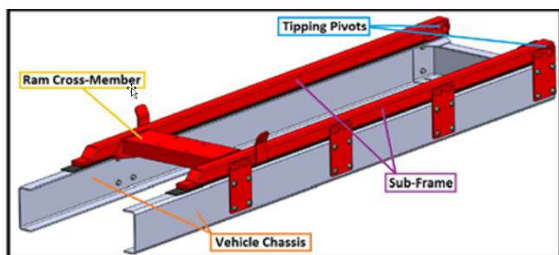

Figure 2 - Basic Tipper Sub-Frame

- The hoist ram cross-member must be of adequate strength to support the tipping hoist ram without deforming under all loading conditions. Some means of strengthening ribs are usually required. (see Figure 3)

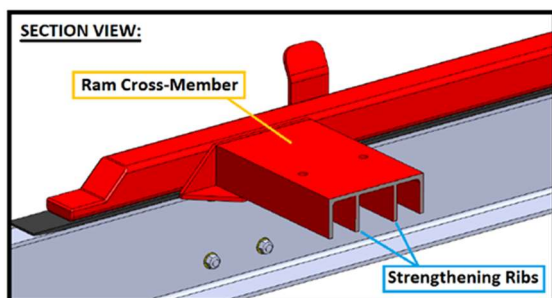

Figure 3 - Cross Section of Ram cross-member with an example of w/strengthening ribs

- A cross-member is required at the rear end of the chassis.
- A tow bar directly mounted between the chassis rails may be used in lieu of a cross member. (In such cases the tow bar design must consider the forces that must be accommodated in keeping with its dual purpose.) A tow bar mounted directly between the chassis rails may be a suitable substitute for a cross-member.
- Mount the brackets for the tipping pivot so that the load is evenly distributed across the chassis.
- Mount the tipping pivots as near as practicable to the rear suspension to reduce loads applied to the chassis during tipping operation.
- Tipping pivot sleeves must be incorporated into the rear mounting plates to prevent tearing out of the pivot walls of the sub-frame. Reinforcing plates must be installed to provide additional support for the tipping pivot sleeves. Where a longer single pivot passing through both pivot sleeves is used, reinforcing is not generally required. However, where two separate pivot pins are used (one for each pivot) suitable reinforcing must be used. (see Figure 4) (Figure 4 is an example of how additional support can be provided for the tipping sleeves.)
- Tipping pin must be suitably restrained to ensure that they do not slide out of the tipping pivot sleeves.

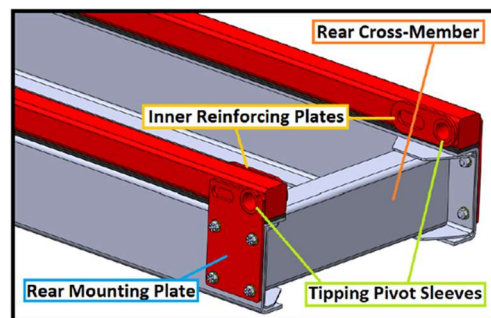

Figure 4 - Example installation of tipping pivot sleeves, reinforcing plates, mounting plates and cross-member

- If support brackets (Figure 5) are used, ensure they are Provide correctly designed support brackets (Figure 5) which to allow the centre line of the body-runners to pass through the centre of any support structure and evenly distribute the load. Provide vertical adjustment or resilient bearer blocks to ensure even distribution of load between all supports when the body is lowered. Correctly designed support brackets (see Figure 5) allow the centre line of the body-runners to pass through the centre of the bracket.

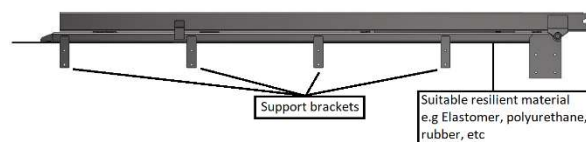

Figure 5 - Typical Support Bracket configuration

Recommended:

- For steel bodies, it is recommended that the body guides (guide vanes) be manufactured from steel, flared out at the top to guide the body into place and welded to the sub-frame. For aluminium bodies, guides should be of a suitable material that minimises damage (eg. rubber guides) may be used.

- Where possible, the original truck cross-member should be retained and/or re installed if the rear cross-member overhang is shortened.
- Use longitudinal packers (of a suitable material) on the chassis to distribute tipper body loads wherever practicable.
- For tipper bodies without longitudinal packers, supports on the chassis should be used at each body cross-member and be at least 450 mm in length each.
- The base of the hoist cylinder should be pin-jointed to a cross-member that is attached to the side rails with bolts through drilled and reamed holes in the vertical webs of the chassis. (see Figure 6)
- Pivots should be supported by the vehicle's chassis.
- The use of Finite Element Analysis (FEA) software to evaluate the strength of the body.

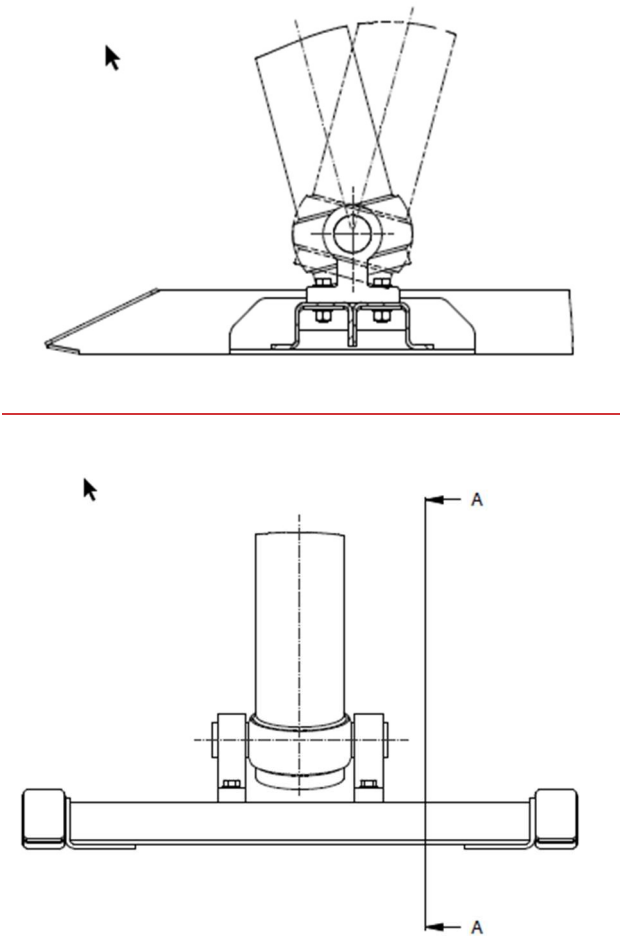

Figure 6 - Typical installation of the hoist cylinder where the ram force (F) acts at a distance (L) from the centre of the bolting configuration and causes a torsional moment ($F \times L$) that must be resisted by the attaching bolts

5. Body Props

A body prop must be fitted to ensure safe operating environment when the empty tipping body is undergoing routine maintenance.

The body prop is not intended to be deployed when the tipping body is loaded.

In the event of hydraulic failure during operation, and the tipping body cannot be unloaded, specialist equipment and appropriate work procedure must be used to conduct repairs in a safe manner.

Required:

A body prop must be fitted that:

- is able to be deployed when the tipping body is at an appropriate angle to facilitate safe servicing of the body hoisting system
- ad-along with its associated hardware, is designed so that strength calculations account for a minimum factor of safety of 2 with respect to the empty weight of the unladen tipping body of sufficient strength to accommodate the weight of the empty tipping body plus a factor of safety of 2, when deployed
- allows easy deployment, without having to excessively reach under the tipping body
- is secured against accidental dislodgement when in use
- when not in use, can be securely stowed either to the tipping body or the vehicles chassis (it is not required to store the prop adjacent to the hoisting ram).

5.6. Tail Gates, Grain and Inspection Chutes.

Required:

- The tailgate and its locking mechanism must be designed to operate without loss of function (such as spillage or the tailgate opening) when the tipping body is in the following condition:
 - The tipping body is loaded to its maximum design carrying capacity plus 25%
 - The tipping body is at its maximum design tilt angle (or the tilt angle it is restricted to by other means).
 - The vehicle being in level ground.
 - The tailgate and its locking mechanism must be designed to operate without loss of function (such as spillage or the tailgate opening) when the equivalent pressure that would be imposed on the assembly:
 - if the body were to be loaded to 1.5 times its maximum water load capacity, and
 - body tilted to not less than 10° above its travel position, and
 - the vehicle being on flat ground.
- ⚠ Consideration for the loading conditions that the tailgate will be subjected to will be dependent upon the material the tipper has been designed and must also take into account partial loading of the tipper body, or mixed loads.

- If the tailgate includes an auxiliary door (grain chute, viewing portal etc.), then the locking mechanisms of the tailgate and auxiliary door (as a system) must be designed to operate without loss of function in the conditions mentioned for tailgates above. If the tailgate includes an auxiliary door (grain chute, viewing portal etc.), then the door and its locking mechanism must be designed to withstand the forces when the equivalent pressure that would be imposed on the door:
 - if the tipping body were to be loaded to 1.5 times the maximum water load capacity, and
 - tilted to its designed maximum tipping angle, and
 - the vehicle being on flat ground.

5.7. Load Cells

Load cells are often incorporated into ram and tipping pivots between the ram cross-member and the ram itself. Therefore, the nature of the loading experienced by the ram cross-member is generally unchanged. However, care must be taken to integrate the load cells into the sub-frame to prevent point loading the rear of the truck chassis.

Some designs include suspension-based load sensing systems. These systems are not required to be certified under the J code. However, depending on their design may require certification under alternative VSB 6 codes.

Required:

- Where load cells are incorporated into the tipping pivot, load cells must be mounted in a manner that maintains the structural integrity. The following are examples of how this might be achieved. Where load cells are incorporated into the tipping pivot, one of the following two options must be used:
 - Option-Example 1:** Tipping pivot/load cell must be mounted onto brackets of adequate strength with a suitable cross-member installed between the brackets (see Figure 7)

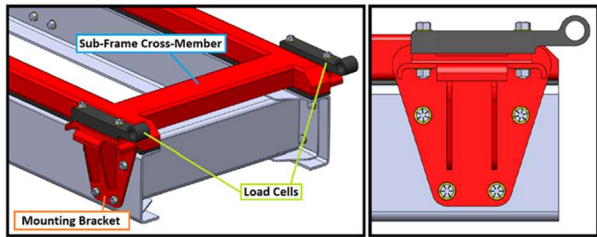

Figure 7 - Option 1 Example: Load cells w/ integrated pivot mounted on brackets & integrated into sub-frame

- Option-Example 2:** A portion of the rear sub-frame can be removed to accommodate the load cell. (see Figure 8 & 9)

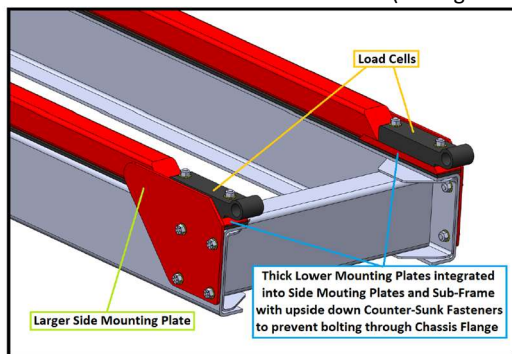

Figure 8 - Load cells with modified sub-frame, lower mounting plates and larger side mounting plates

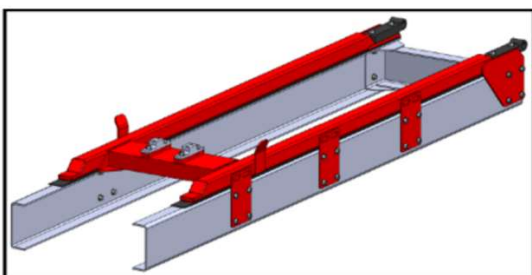

Figure 9 - Tipper sub-frame with integrated load cells

- Load cells are mounted using upside down countersunk fasteners with a minimum ISO Grade 8.8 (or SAE Class 5), appropriate grade washers and self-locking nuts (see AS 1110.1) high tensile fasteners. (see Figure 10)

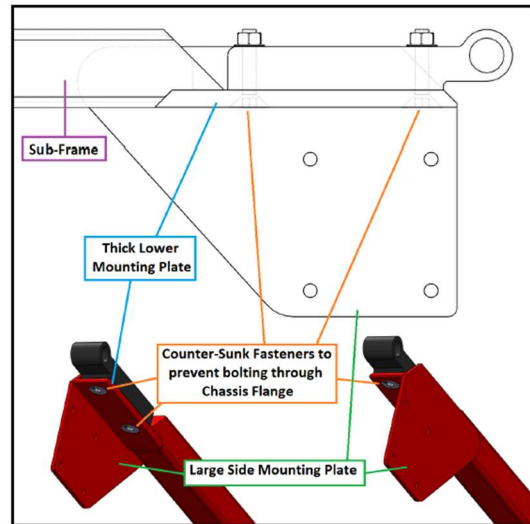

Figure 10 - Countersunk fasteners to prevent bolting through chassis frame

- Lower mounting plates are to be integrated into the sub-frame.
- Side mounting plates must be extended forward of the region where the sub-frame was removed.
- Edges of the sub-frame, lower mounting plates and side mounting plates must overlap – i.e. not located in the same vertical plane) and must be tapered to provide gradual change in stiffness.
- Drilling of top or bottom chassis flange to mount load cell is not permitted.

7.8. Hydraulics/Pneumatics

Required:

- The general design principles of AS1418.8 Clause 4.4.1 must be followed, with the following specific design considerations for tippers.
 - Individual hydraulic fittings and hoses must meet applicable recognised standards
 - When there is a complete loss of pressure in the hydraulic system (hose burst etc.), the lifting hoist must either:
 - immediately stop moving; or
 - automatically lower at a rate not faster than its typical operating speed; or
 - the lifting command on the control is disabled or made ineffective. Lowering of the body can be achieved in a controlled manner by applying the usual lowering command on the control. The operator will be deemed to “have control” if the operator can stop and restart the decent of the body at any point.
 - Where a system is design to immediately stop moving in the event of complete loss of pressure and the release mechanism is in a position that may put operators in an unsafe position place a label advising such
 - In the event where the tipper has controls external of the cabin (either mechanical or electronic remote control) or are designed to be operated from outside the cab (eg located in the cabin but between the seat and the door), the ability to automatically lower (at any rate) is not permitted.
 - If the tipper body is designed to immediately stop moving where a complete loss of pressure is experienced, it may only be lowered in one of the following ways:
 - from a location outside the cab that does not place the operator or the repairer in an unsafe situation.

~~— from within the cab using the usual tipping control, provided that lowering of the body can be achieved in a controlled manner by applying the usual lowering command on the control.~~

- Where the power supply of an accessory, such as a powered tail gate or its lock, is interrupted through electrical or mechanical failure, the accessory must not continue to operate in an uncontrolled manner. (e.g. powered tail gate must not automatically close (or move) when de-energised).
- An accessory may return to a neutral position automatically when de-energised only if it would not pose a safety risk.
- ~~Pneumatic and hydraulic lifting systems must incorporate over pressure protection. This ought to be set at 10% or more below the lowest rated component in the hydraulic/pneumatic system and -In addition, it should be suitable for the maximum operating hydraulic circuit flow rate. Pneumatic and hydraulic lifting systems must incorporate over pressure protection as outlined in AS1418.8 and in accordance with the cylinder manufacturer's requirements.~~
- Once hydraulic pressure, corresponding to the tipping body (including an acceptable overpressure) is reached, the tipping mechanism must stop operating.
- Where a pressure relief valve is used it must have adequate flow to prevent overload under every engine operating condition.
- Unless the air supply is derived from the truck's air systems, air pneumatic filter/separators must be provided and be sized to provide at least 1000 hours operation between services (preferably with condition indicators).
- Tipping bodies or accessories which use the truck's compressed air for their operation, must be designed to be compatible with the normal nominal operating pressure of the truck pneumatic system.
- Air supply must be taken from a pressure protected supply as per requirements of Section G.
- Hoses and fittings must be sized accordingly, or appropriate pressure reducers fitted as required and meet recognized standards.
- ~~Hydraulic filters must be fitted and have the ability to be changed without disturbing hoses or emptying the tank.~~
- ~~The Return lines to hydraulic tank return circuit must be designed in a way that minimizes the possibility of oil aeration; return below the normal oil level (not into free air, e.g. top of tank).~~
- Hoses need to be of the correct pressure rating sized adequately to prevent:
 - Cavitation
 - Starvation; and
 - Undue temperature rises of the fluid in the system.
- ~~Hydraulic tanks must:~~
 - ~~— have a level indicator (e.g. a decal, plates or marking) next to the filling position showing maximum and minimum levels under operational conditions.~~
 - ~~— hold a minimum amount of oil for full ram displacement plus 2530%.~~
- Components, gauges, pressure test point or any other item requiring daily monitoring or adjustment, must not be placed in locations requiring the operator to access the under body of the vehicle. ~~If any of these items require the lifting of the body, they must be accessible when the body prop is deployed.~~
- Provision must be made to bleed air from the system/hoist if applicable.
- ~~Twin underbody ram tippers must have suitable valving to protect against overload in the event of one cylinder losing pressure.~~

- Provide comprehensive and easily understood installation and maintenance instructions for the tipper body to allow an accredited J1 AVE to certify their installation. These instructions are to include a circuit diagram for the hoisting system as per AS1418.8 Clause 4.5, indicating test points where fitted.

• ~~Hydraulic tanks must:~~

- ~~– have a level indicator (e.g. a decal, plates or marking) next to the filling position showing maximum and minimum levels under operational conditions.~~
- ~~– hold a minimum amount of oil for full ram displacement plus 30%.~~
- ~~The hydraulic tank return circuit must be designed in a way that minimizes the possibility of oil aeration.~~

Recommended:

- A red tell-tale light in the vehicle cab which indicates when the overpressure set point is reached.
- Hoses should be shield (which can include by body work, chassis, etc) to reduce direct exposure to personnel in the event of failure where:
 - fluid pressure is above 5 MPa (726 PSI); or
 - fluid temperature is above 50°C and where direct exposure to personnel is possible in the event of failure, should be shielded.
- Where hydraulic components are fitted that are sensitive to debris in the system, hydraulic filters should be ~~must be fitted.~~
- If hydraulic filters are fitted they should ~~and~~ have the ability to be changed without disturbing hoses or emptying the hydraulic tank.
- Hydraulic tanks should:
 - ~~— be fitted with a strainer/breather that cannot be removed without tools.~~
 - provide adequately protected and accessible provisions to facilitate emptying of the tank without spillage, complete cleaning or requiring pumping out of fluid.
 - hold a minimum amount of oil for full ram displacement plus ~~2530~~ 30%.

9.9. Alarms, warnings and lockout features

Recommended:

- Tailgates fitted with positive locking mechanisms (mechanical, air or electric) ~~must~~ be fitted with a visible and/or audible tell-tale located at the tipper controls which warns the operator when:
 - the tail gate is locked, and the front of the tipping body is in the raised condition (50mm or more above its transport position); or
 - automatically unlock the tail gate when the body begins to rise. If this feature is present.

9.10. Controls

Required:

- Control systems must provide fail-safe operation at all times (including during a failure the system, power supply, etc.)
- If the tipping body is not designed to tip in motion, ~~or the controls are designed to allow operation from outside the cab (eg located in the cabin but between the seat and the door), a the control device for the tipping body should be fitted within the vehicle cabin complying with must AS1418.4 clause 4.6.2.1 and:~~
 - be positive in motion hold-to-run type; and
 - return to neutral when released

- If the tipping body is designed to tip in motion either
 - a body interlock system must ~~should~~ be fitted that stops the vehicle moving at a speed greater than 205km/h if the body is not in its transport position; or
 - ~~A body up alarm and visual warning in the cab, that activated when the body is not in its transport position.~~

It is understood that in many cases return to neutral and hold to operate controls in certain tipper applications is not practical or safe. For example:

- ~~Truck and dog configuration where the vehicles tipping control must be moved and maintained in a position that establishes and maintains hydraulic flow to the dog trailer, to enable tipping body of the trailer to operate.~~
- Side tipping applications where the operation of other equipment requires hydraulic flow to remain established and additional controls must be used to operate hydraulic powered equipment (eg side gates).
- Tipping in motion where the vehicle must continue to move while tipping and driver must continue to steer the vehicle.

Section J4 permits the fitting of controls that are not “return to

- If controls are fitted in multiple locations, interlocks must be fitted to ensure only one set of controls can be used at once.
- If external mechanical controls or the controls designed to allow operation from outside the cab (eg located in the cabin but between the seat and the door) are fitted, they must:
 - be able to be secured from accidental operation by a locking mechanism when not in use;
 - not operate the tipping body whilst the vehicle is in motion; and
 - not be located in a position hazardous to the operator when used.
- If any pendant or remote control is fitted, they must:
 - be fitted in an appropriate enclosure with no less than IP55 rating;
 - return to the off position if the control is released, detached or broken;
 - not allow unintended movement due to failure of the controls (monitored outputs);
 - have an emergency stop that initiates within 550ms of being pressed;
 - shutdown the system within 550ms if no valid signal is received from the transmitter;
 - have key-stop to 'off' position;
 - shut down if transmitter is out of range;
 - have battery life indicator (if fitted with a battery) that gives warning at least 5 minutes prior to turning off;
 - turn off if no functions have been used for 5 minutes; and
 - not be able to be initiated unless all motion actuators are in the 'off' position (buttons/switches/ hydraulic valves, etc.)

Recommended:

- If a vehicle has controls that are located externally (or remote control) the tipping body should be interlocked to prevent tipping in motion when the external control is being used.

10.11. Wiring

Required:

- Wiring must be enclosed in materials suitable for the typical operating environment of the tipper-operates.

- Ensure wiring follows the manufacturer’s requirements (CAN protocol, etc); or if not available, applicable-ADR 42/.ustralian Standards.

11.12. Marking

- The hoisting system shall display, at a readily accessible and prominent location/s and on permanent and legible notices, the following information, as appropriate:
 - Name or mark of the manufacturer or distributor of the hoisting system.
 - Model designation of the hoisting system.
 - Owner’s identification number of the hoisting system.
 - A notice stating that ‘PERSONS SHALL NOT WORK UNDER THE RAISED TIPPING BODY/TRAY UNLESS THE BODY/TRAY HAS BEEN SECURELY CHOCKED OR OTHERWISE SECURED’; and
 - Where applicable, a notice stating ‘PERSONNEL SHALL NOT RIDE ON THE TIP TRUCK’

12.13. Stability

Recommended:

A rigid truck, fitted with a tipping body, should have an overturn angle of 7° or more. This can be met in a variety of ways, some of which are included below.

It is impossible to foresee all operating conditions that a vehicle fitted with a tipping body due to the broad range of environmental factors such a vehicle will encounter. This may include:

- Construction sites with uneven and soft ground
- Wet and muddy work sites
- Hard uneven surfaces
- Hard level surfaces

When assessing the design, the best-case scenario should be considered to provide a baseline pro-forma criterion. They will not result in a safe vehicle in all operating conditions.

Equipment

- The vehicle maybe fitted with a device, such as an inclinometer, that:
 - is interconnected with the tipping mechanism and will prevent the body from raising any further if loss of side stability is detected.
 - The inclinometer outputs a signal to a buzzer or other sound generator within the vehicle cabin which may also incorporate a tell-tail.

Many electronic brake systems have a stability function incorporated with an output that can be utilised to activate a warning signal (buzzer, light etc) or interlock. This signal may be used in lieu of a dedicated inclinometer if performed in accordance with the brake manufacturer’s requirements.

Calculation

- The vehicle’s design should be assessed using calculations to ensure an overturn angle of at least 7°.
- One calculation method is provided -outlined- in Section 14, however suitably qualified AVEs may choose to use alternate stability calculation methods-to ensure an overturn angle of at least 7°. These calculations assume:
 - the tipping body is loaded with a simulated water load to the trucks’ maximum GVM
 - the body is in its fully tipped position.

- Wind loads are considered for the purposes of AS1418.8 Clause 4.3, unless the lifting ram accepts only axial loads.

13.14. Stability calculations

Calculation of stability follows a similar methodology that is used to determine static roll threshold (SRT) under the Performance Based Standard scheme. (see Figure 12) The example and methodology explained below demonstrates a rear acting tipping body. A similar methodology can be used to determine stability on a side tipping body.

Recommended:

- The RST threshold value that corresponds to a 7° overturning angle or side slope is 0.123g.
- To determine if the tipper design conforms to the stability values, the following data is required:
 - Torsional resistance of the chassis frame rear hinge point to the rear suspension centreline.
 - Roll stiffness of the suspension at the point of wheel lift on one side
 - Width of effective spring base
 - Height of suspension roll centre

Dimensional Data:

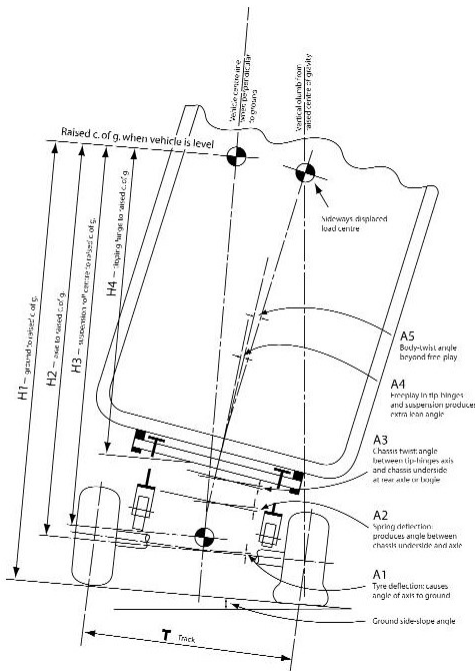

Figure 12

H1 – the height from the ground to the centre of gravity of a fully-raised load in the body when the vehicle is standing on level ground.

H2 – the height of that level ground centre of gravity above the centre line of the rear axle.

H3 – the height of that level-ground centre of gravity above the roll centre of the rear suspension.

H4 – the mean height of the centre of gravity of the load in the raised body above the tipping hinges

H5 – height of tip hinge above ground level

A1 – Angle of axle to the ground caused by tyre deflection

A2 – Angle of axle and chassis underside cause by spring deflection

A3 – Chassis twist angle between tip hinge axis and chassis underside at the rear axle or at bogie center

A4 – Angle between and suspension cause by free play in tip hinges

A5 – angle due to tip body twist beyond free play of tip hinges

B – the height of the centre of gravity above the hinge point

L – the distance between the center of gravity and the hinge point

T – Track (for dual tyre track is taken from the center of the two tyres)

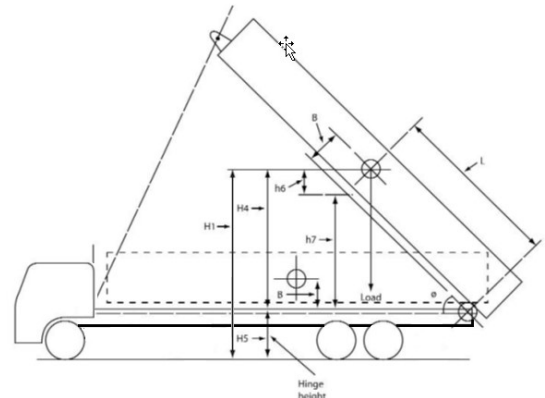

Figure 12

Simulated load:

The simulated load is taken to be where:

- The mass loaded in the bin takes the truck to its maximum rated GVM.
- The load is taken to occupy the entire volume of the bin. Therefore, the centre of gravity of the load will be located at the mid points of the width, length and height of the body.

Calculation of height of the raised centre of gravity:

To calculate the height of the raised centre of gravity (H1):

$$h6 = B \cos \theta$$

$$h7 = L \sin \theta$$

$$H4 = h6 + h7 = B \cos \theta + L \sin \theta$$

$$H1 = H4 + H5$$

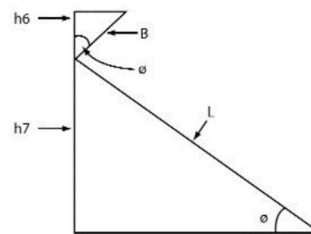

Calculation of overturn angle:

The overturning angle (OA) can be calculated as follows:

$$OA = \sin^{-1} \left\{ \frac{(T \div 2) - (H2 \times \sin A2) - (H3 \times \sin A3) - (H4 \times \sin A4) - (H4 \times \sin A5)}{H1} \right\}$$

Side tipping and multi tipping bodies:

Side tipping bodies – the stability calculation on a side tipping body follows the same methodology as a rear tipping body. If the side tipper has the ability to tip on either side of the vehicle, the stability calculation should be performed in each operating

condition if the tilting mechanism geometry differs from side to side.

Multi tipping bodies – the stability calculations should be performed in all tipping configurations. If the geometry of the side tipping function between left and right is different, separate calculations must be done.